

PaintShop Pro Tutorials

By Maureen Eves-Lavis

TITLE : ARTY TEXT

Software: PaintShop Pro X6

My Web Site: [Creative-Designs](http://Creative-Designs.com)

Materials Required: None



DESCRIPTION

Create interesting styles of text. Separate characters by applying Convert Text to Curves and adding gradients or patterns. Learn how to make Word Art too!

Remember to save your work often to avoid losing it

BASIC TEXT

1. Open a new raster image of 800x350 pixels, resolution at default.
2. Select a foreground colour of yellow and a background colour of blue.

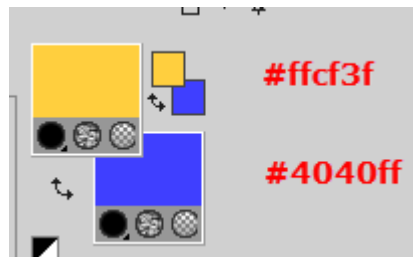

3. Select the Text Tool, pick fairly thick font and apply these settings:
 - Size of 60 Points (I add the 60 manually)
 - Alignments: Left
 - Direction: Horizontal and Down

- Anti-alias: Sharp
- Width: 4.0
- Line Style: Solid
- Auto-Kern: Unticked
- Kerning: 225 (Adjust accordingly)
- All other settings as is

Type the word TEXT. It is nice and big and bold.

TEXT

4. Change to the Pick tool, go to Objects, Align, Horizontal Centre in Canvas.

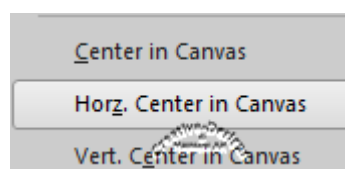

5. Take a look at Vector 1 Layer, on the left of the layer is a small arrow, click it to open. Beneath is a sub-layer.

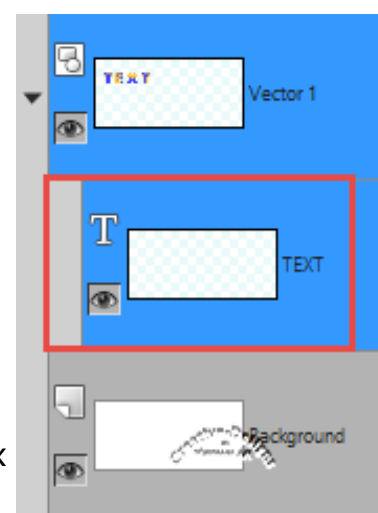

- 6 Select the TEST layer, not the Vector 1 layer. A bounding box will surround the word on the canvas.

7. Go to Objects, Convert Text to Curves, As Character Shapes.



8. Each letter has been placed on its own layer. Each layer also has a small symbol, telling you that this shape is now a path shape. Each letter can be saved to your Preset Shapes folder, if you wish. How did I do this?

EXPORT - LETTERS AS PRESET SHAPES

1. Select the letter T. A bounding box will appear around the letter. Go to file, Export, Shape. When the dialogue window opens I added my initials and large T. Click Ok.

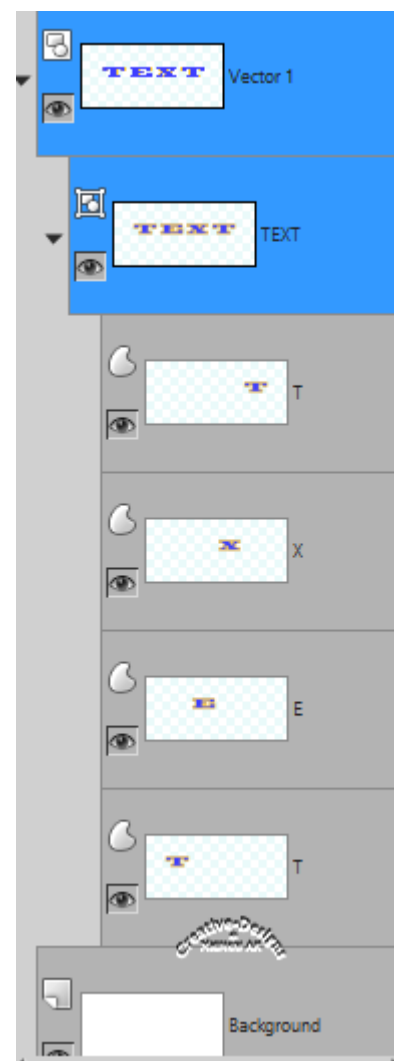
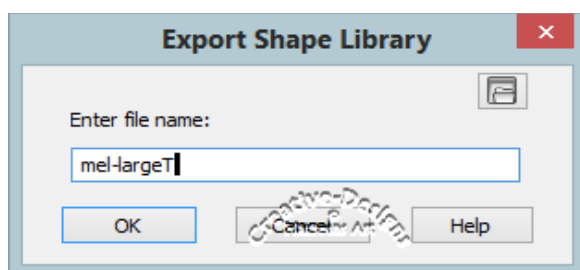
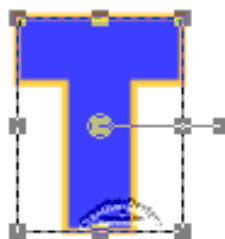

2. To see the T shape, select the Preset Shape tool from the toolbar. Open the Presets drop list on the Tools Options palette. Preset Shapes - and there you will see the letter



3. You can create the alphabet and save each letter as a Preset Shape. You can use the letters over and over again with or without the saved colours by changing the foreground and background colours, including gradients and patterns, by unticking Retain style, you can have a very fancy set of letter characters - numbers also can be used the same way.

I have deviated, but I thought it would be a good time to tell you there are many things you can do with letters and numbers.

EDITING AND ENHANCING THE TEXT

Let's get back to our TEXT and apply some editing and enhancements.

1. Select the letter T layer just above the background layer. Change to the Pen Tool. The letter T is showing nodes. I'm going to adjust some of these nodes. When I am happy with the edit, I click the Apply button.

You go through each of the letters adjusting nodes to make the text look a little quirky yet artistic. Have fun!

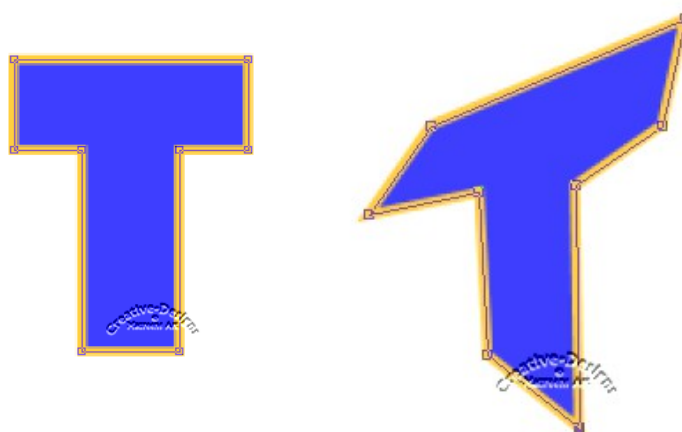

2. If you wish to add a node, hold the Ctrl key and click down on the contour. You will see ADD. Sometimes editing nodes can be a little tricky, so it's best to zoom in whilst moving nodes around.



3. Double click on each layer in turn and increase the Stroke width to 6.

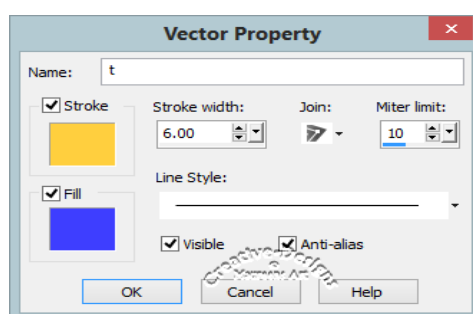

4. Select the Magic Wand, Match mode Colour, Tolerance 20, Use All Layers unticked, Contiguous ticked, Feather 2, Anti-alias ticked and Outside selected. The blue on the letter T has a marquee. Go to Effects, 3D Effects, Inner Bevel, Bevel 2, and apply the below settings:

Click OK.

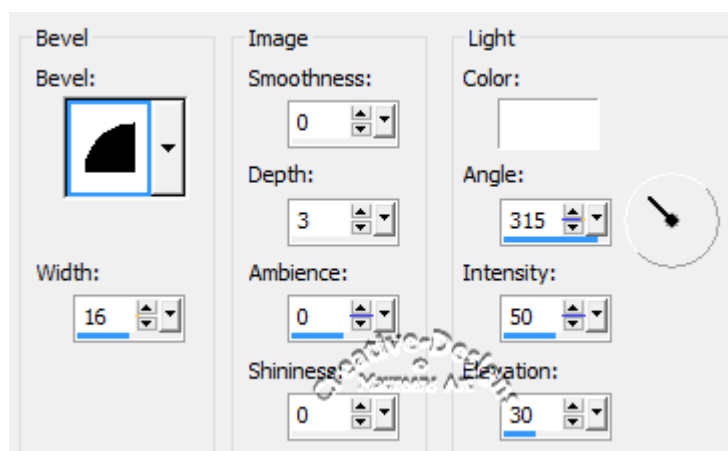

5. Double click the letter E in the Layers Palette. On the Vector Property, change the Fill to a pattern. Go through each letter and apply materials that you like. Increase or decrease the stroke or change the colour to a gradient or pattern.

6. My image below contains the T with the pillow effect. I magic wand the edge and applied Artistic Effects, Neon, Extreme. The E I filled with a pattern. Magic wand the edge and applied Texture Effects, Emboss. The X I filled with a metal pattern. Magic wand the edge and applied a bevel edge. Lastly, the T which I filled with a gradient and added a Duotone to the stroke. Now, it's your turn!



WORD ART

1. Open a new Raster white image at 1000x900 pixels. Resolution at default.
2. On the Materials palette, click Set to Black and White button. Make the background colour to transparent.
3. You will need the rulers and guidelines for this tutorial. If you do not have them selected, go to View, tick Rulers and Guides.



4. From the top ruler, click down until the cursor changes. Drag the guide to 150. If you aren't sure of the right measurement, double click on the guide's little blue bar on the left ruler. It will open the Guide Properties dialogue window. Type in 150. Click Ok.

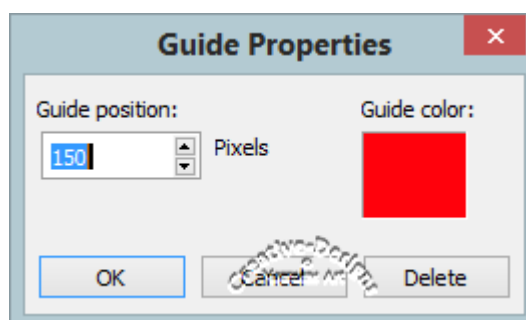
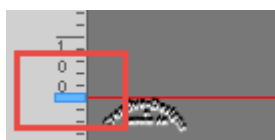

5. Drag another guide down to 550, again, double click on the blue bar to make sure it is 550 pixels. Click Ok. Now the guides are in place.
6. Select the Pen Tool and apply the following settings:
 - Create on a Vector: Ticked
 - Connect Segments: Ticked
 - Show Nodes: Ticked
 - Line Style: Solid
 - Width: 2
 - Anti-alias: Ticked

6. Click the Point to Point / Bezier tool. Click down on the lower guide, left edge. Draw upwards, then stop, draw down to the guide again. Lift the pen. Grab hold of the control arm and pull up to arc the shape more as shown in the image below.

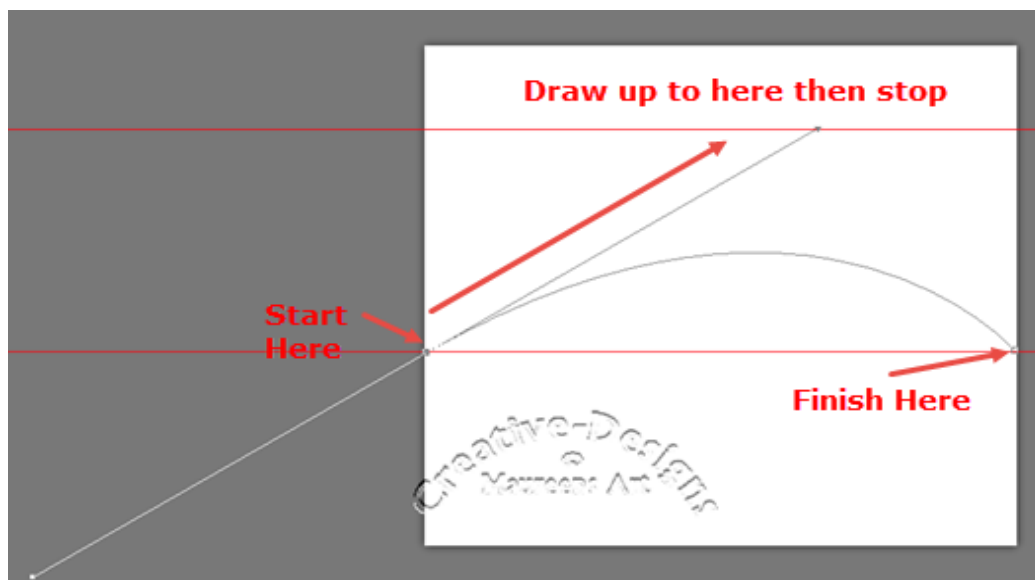

7. Pull a guide from the left ruler to the centre - 500 pixels.

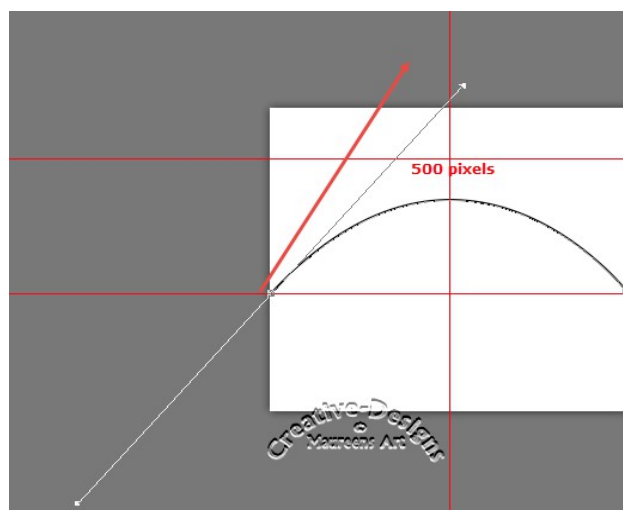

8. When you are satisfied with the shape, click the Apply button on the Tools Options palette. Change to the Pick Tool.
9. Add a new Vector layer and move it to the top of the layer stack. Keep this layer highlighted.

10. Select the Text tool and choose a fairly large font. Size, 30 Points. The current Stroke Width for text is set at 4, reduce it to 2.0. Create Text on a Vector with Auto-Kern ticked. Warp text should be ticked too.

11. Go to the Materials palette and choose a navy blue for the foreground. For the text fill, I will use a gradient. I selected a pretty blue and white gradient that will blend nicely with the stroke. Choose Linear Style and change the Angle to 45 degrees.

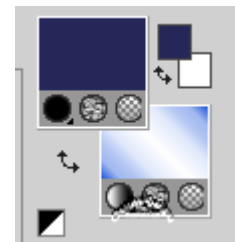

12. Begin on the left side of the canvas, type Word Art as shown below. Click on the text, go to Objects, Align, Horizontal Centre in Canvas. Right click the text layer and Convert to Raster Layer.

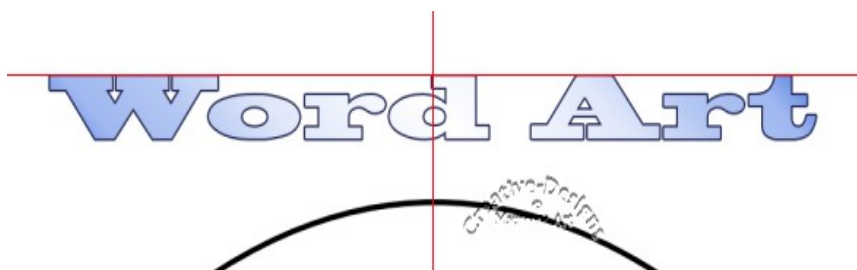

13. Now for the fun part. Select the Mesh Warp. Change the Mesh horizontal 9 and vertical 10 - on the Tools Options palette. Tick Show mesh. Edge mode - Medium and Final apply - Best quality.

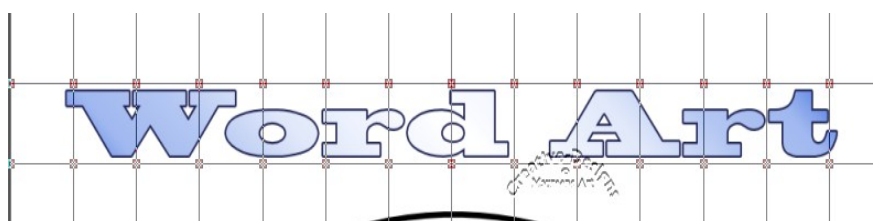
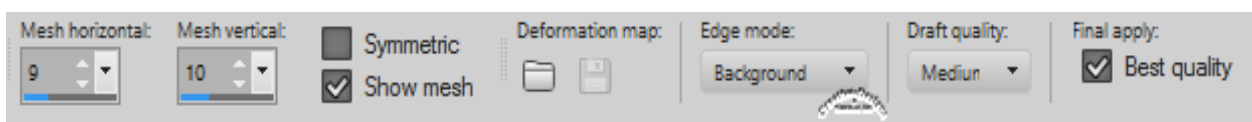

14. Before warping the text, a few nodes need to be moved. I can't delete them but I can pull them away. Starting on the right, move the lowest node and pull down. You must begin at the lowest nodes, then the next level up and then the next level up until they look like the images below.

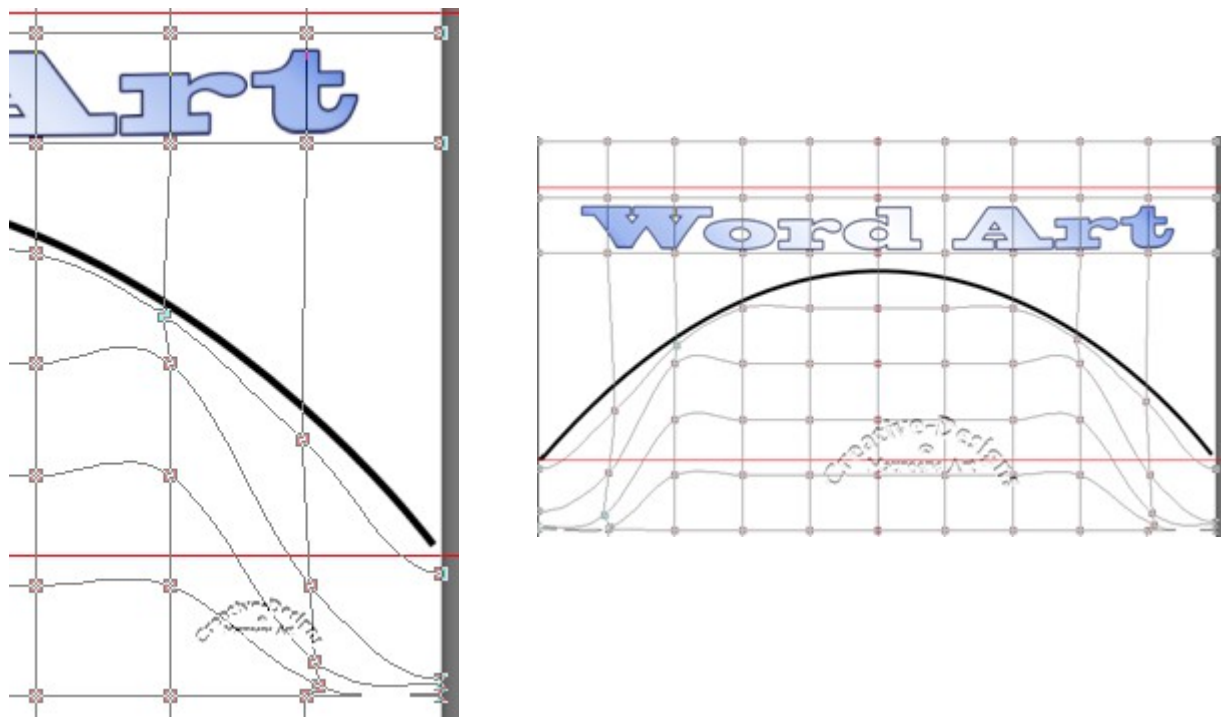

15. Begin pulling down the nodes under the text. Pull each node straight until it rests on the black line. When you are happy with the text, click the Apply button and change to the Pick Tool. The Warp Mesh is now gone.

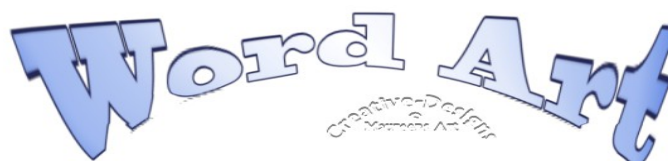

16. To remove the Guides, click on the little blue bar to open Guide Properties, click the Delete button.

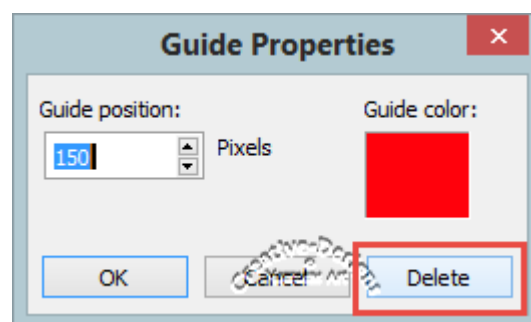

17. Delete the Vector 1 layer with the arc as it is no longer required.
18. I applied a 3D Effect, Bevel 2, Width 16, Smoothness 0, Depth 3, Ambience 0, Shininess 0, Colour white, Angle 315, Intensity 50 and Elevation 30. Added a shadow of 12 Vertical, 9 horizontal, 50 Opacity and 5 Blur.

You are not limited in text styles, fills and borders as well as the many Effects that PaintShop Pro provides. Enjoy and have fun creating artistic style text.

This completes the Artistic Text Tutorial. I hope you have enjoyed it.



To learn more about PaintShop Pro, join the free Beginner's Workshop for PaintShop Pro [HERE](#).

Also, you are welcome to join the PIRC Forums where there is a great community of graphic artists all learning together [HERE](#).